

1. Module detail and its structure

Subject Name	Physics
Course Name	Physics 03 (Physics Part 1 Class XII)
Module Name/Title	Unit-03, Module-08: Magnetic Dipole Moment Chapter-05: Magnetism and Matter
Module Id	Leph_10501_eContent
Pre-requisites	Electric Current and moving charges are associated with magnetic field, Biot-Savart's law, Amperes law, magnetic field lines, electric dipole and the electric field around it, torque on an electric dipole placed in a uniform electric field, Magnetic field.
Objectives	<p>After going through this module, the learners will be able to:</p> <ul style="list-style-type: none"> • Compare electric and magnetic dipoles • Understand that a current loop is a magnetic dipole • Express magnetic dipole moment and electric dipole moment p • Derive the value of magnetic field strength B at a location around a bar magnet • Use gauss's law for magnetism to show magnetic monopoles do not exist the dipole moment of a revolving electron in an atom
Keywords	Circular current loop as a magnetic dipole, electronic movement magnetic dipole, torque on a magnetic dipole in a magnetic field

2. Development Team

Role	Name	Affiliation
National MOOC Coordinator (NMC)	Prof. Amarendra P. Behera	Central Institute of Educational Technology, NCERT, New Delhi
Programme Coordinator	Dr. Mohd Mamur Ali	Central Institute of Educational Technology, NCERT, New Delhi
Course Coordinator / PI	Anuradha Mathur	Central Institute of Educational Technology, NCERT, New Delhi
Subject Matter Expert (SME)	Anuradha Mathur	Central Institute of Educational Technology, NCERT, New Delhi
Review Team	Associate Prof. N.K. Sehgal (Retd.) Prof. V. B. Bhatia (Retd.) Prof. B. K. Sharma (Retd.)	Delhi University Delhi University DESM, NCERT, New Delhi

TABLE OF CONTENTS

1. Unit syllabus
2. Module wise distribution of unit syllabus
3. Words you must know
4. Introduction
5. Circular current loop as a magnetic dipole
6. Magnetic dipole moment of a revolving electron
7. Bar magnet as an equivalent solenoid
8. Torque on a current loop or magnetic dipole in a uniform magnetic field
9. Application of torque on a magnetic dipole placed in a magnetic field
10. Magnetism and Gauss's Law
11. Summary

1. UNIT SYLLABUS

UNIT 3: Magnetic Effects of Current and Magnetism

Chapter-4: Moving Charges and Magnetism

Concept of magnetic field, Oersted's experiment.

Biot – Savart's law and its application to current carrying circular loop.

Ampere's law and its applications to infinitely long straight wire. Straight and toroidal solenoids, Force on a moving charge in uniform magnetic and electric fields. Cyclotron.

Force on a current-carrying conductor in a uniform magnetic field. Force between two parallel current-carrying conductors-definition of ampere. Torque experienced by a current loop in uniform magnetic field; moving coil galvanometer-its current sensitivity and conversion to ammeter and voltmeter.

Chapter-5: Magnetism and Matter

Current loop as a magnetic dipole and its magnetic dipole moment. Magnetic dipole moment of a revolving electron. Magnetic field intensity due to a magnetic dipole (bar magnet) along

its axis and perpendicular to its axis. Torque on a magnetic dipole (bar magnet) in a uniform magnetic field; bar magnet as an equivalent solenoid, magnetic field lines; Earth's magnetic field and magnetic elements.

Para-, dia- and ferro - magnetic substances, with examples. Electromagnets and factors affecting their strengths. Permanent magnets.

2. MODULE WISE DISTRIBUTION OF UNIT SYLLABUS 10 Modules

The above unit is divided into 10 modules for better understanding

Module 1	<ul style="list-style-type: none"> • Introducing moving charges and magnetism • Direction of magnetic field produced by a moving charge • Concept of Magnetic field • Oersted's Experiment • Strength of the magnetic field at a point due to current carrying conductor • Biot-Savart Law • Comparison of coulomb's law and Biot Savarts law
Module 2	<ul style="list-style-type: none"> • Applications of Biot- Savart Law to current carrying circular loop, straight wire • Magnetic field due to a straight conductor of finite size <p>Examples</p>
Module 3	<ul style="list-style-type: none"> • Ampere's Law and its proof • Application of amperes circuital law: straight wire, straight and toroidal solenoids. • Force on a moving charge in a magnetic field • Unit of magnetic field <p>Examples</p>
Module 4	<ul style="list-style-type: none"> • Force on moving charges in uniform magnetic field and uniform electric field. • Lorentz force • Cyclotron

Module 5	<ul style="list-style-type: none"> • Force on a current carrying conductor in uniform magnetic field • Force between two parallel current carrying conductors • Definition of ampere
Module 6	<ul style="list-style-type: none"> • Torque experienced by a current rectangular loop in uniform magnetic field • Direction of torque acting on current carrying rectangular loop in uniform magnetic field • Orientation of a rectangular current carrying loop in a uniform magnetic field for maximum and minimum potential energy
Module 7	<ul style="list-style-type: none"> • Moving coil Galvanometer- • Need for radial pole pieces to create a uniform magnetic field • Establish a relation between deflection in the galvanometer and the current • its current sensitivity • Voltage sensitivity • Conversion to ammeter and voltmeter <p>Examples</p>
Module 8	<ul style="list-style-type: none"> • Magnetic field intensity due to a magnetic dipole (bar magnet) along its axis and perpendicular to its axis. • Torque on a magnetic dipole in uniform magnetic field. • Explanation of magnetic property of materials
Module 9	<ul style="list-style-type: none"> • Dia, Para and ferro-magnetic substances with examples. Electromagnets and factors affecting their strengths, permanent magnets.
Module 10	<ul style="list-style-type: none"> • Earth's magnetic field and magnetic elements.

MODULE- 08

3. WORDS YOU MUST KNOW

- **Coulomb's law:** The mutual force of attraction or repulsion between two point charges is directly proportional to the product of two charges (q_1 and q_2) and inversely proportional to the square of the distance between them. It acts along the line joining them.
- **Electric current:** The time rate of flow of charge.
- **Electric dipole:** A pair of **electric** charges of equal magnitude but opposite sign, separated by a small distance
- **Dipole moment p :** The electric dipole moment points from the negative charge towards the positive charge, and has a magnitude equal to the strength of each charge times the separation between the charges.
- **Dipole field:** The space around the dipole where its influence is felt by a small test charge.

Dipole field E along its axis:

$$E = \frac{2p_e}{4\pi\epsilon_0 x^3}$$

And along a line perpendicular to the dipole axis:

$$E = \frac{p_e}{4\pi\epsilon_0 x^3}$$

- **Torque on an electric dipole:** When placed in an external electric field though the net force on the dipole is zero, it experiences a torque:

$$\tau = p \times E$$

- **Magnetic field lines:** it is a curve, the tangent to which at a point gives the direction of the magnetic field at that point.

4. INTRODUCTION

We know that Magnetic phenomena are universal in nature. Vast, distant galaxies, the tiny invisible atoms, men and beasts all are permeated through and through with a host of magnetic

fields from a variety of sources. The earth's magnetism predates human evolution. The word magnet as you may recall, is derived from the name of an island in Greece called *magnesia* where magnetic ore deposits were found, as early as 600 BC. Shepherds on this island complained that their wooden shoes (which had nails) at times stayed stuck to the ground. Their iron-tipped rods were similarly affected. This attractive property of magnets made it difficult for them to move around.

The directional property of magnets was also known since ancient times. A thin long piece of a magnet, when suspended freely, pointed in the north-south direction. A similar effect was observed when it was placed on a piece of cork which was then allowed to float in still water. The name *lodestone* (or *loadstone*) given to a naturally occurring ore of iron magnetite means leading stone.

The technological exploitation of this property is generally credited to the Chinese. Chinese texts dating 400BC mention the use of magnetic needles for navigation on ships. Caravans crossing the Gobi desert also employed magnetic needles.

Some of the commonly known ideas regarding magnetism are:

- (i) The earth behaves as a magnet with the magnetic field pointing approximately from the geographic south to the north.**
- (ii) When a bar magnet is freely suspended, it points in the north-south direction. The tip which points to the geographic north is called the *North Pole* and the tip which points to the geographic south is called the *south pole* of the magnet.**
- (iii) There is a repulsive force when north poles (or south poles) of two magnets are brought close together. Conversely, there is an attractive force between the north pole of one magnet and the south pole of the other.**
- (iv) We cannot isolate the north, or South Pole of a magnet. If a bar magnet is broken into two halves, we get two similar bar magnets with somewhat weaker**

properties. Unlike electric charges, isolated magnetic north and south poles known as *magnetic monopoles* do not exist.

(v) It is possible to make magnets out of iron and its alloys.

THE MAGNETIC FIELD LINES

The pattern of iron filings permits us to plot the magnetic field lines. This is shown for the bar-magnet, the current-carrying solenoid and an electric dipole in figure.

The magnetic field due to a section of the solenoid which has been stretched out for clarity. Only the exterior semi-circular part is shown. Notice how the circular loops between neighbouring turns tend to cancel and you can observe the magnetic field of a finite solenoid.

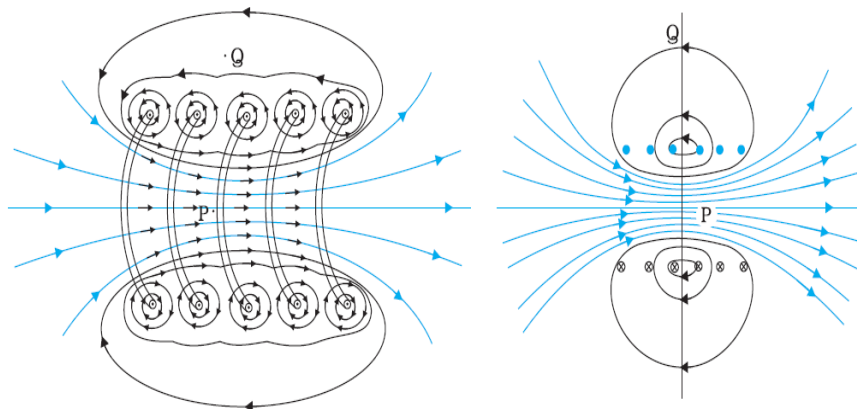
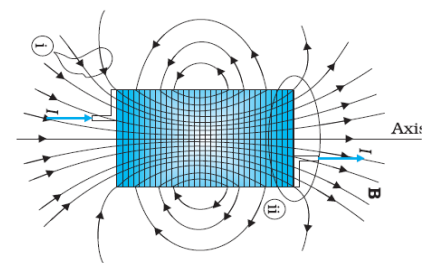
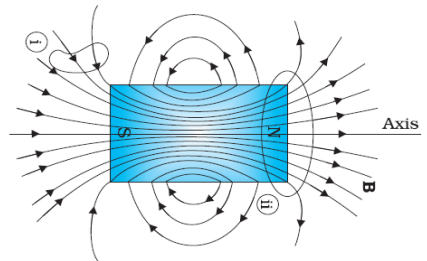

Compare the above field lines due to a magnet or a solenoid with field line of an electric dipole. Electric field lines of an electric dipole displayed in the figure.

Like the electric field lines, magnetic field lines are a visual and intuitive realisation of the magnetic field.

Properties of magnetic field line :

- (i) The magnetic field lines of a magnet (or a solenoid) form continuous closed loops. This is unlike the electric dipole where these field lines begin from a positive charge and end on the negative charge or escape to infinity.
- (ii) The tangent to the field line at a given point represents the direction of the net magnetic field B at that point.
- (iii) The larger the number of field lines crossing per unit area stronger is the magnitude of the magnetic field B , identify the regions of greater magnetic intensity from the figure.
- (iv) The magnetic field lines do not intersect, for if they did, the direction of the magnetic field would not be unique at the point of intersection.

One can plot the magnetic field lines in a variety of ways. One way is to place a small magnetic compass needle at various positions and note its orientation. This gives us an idea of the magnetic field direction at various points in space.

Now we will understand how a magnetic dipole can be compared to an electric dipole

5. CIRCULAR CURRENT LOOP AS A MAGNETIC DIPOLE

In this section, we shall consider the elementary magnetic element: the current loop. This is just a conductor wire turned into a loop the two open ends can be connected in any circuit to make current flow through it, the current could be varying or steady. We will limit our study to steady current in the loop .We shall show that the magnetic field (at large distances) due to current in a circular current loop is very similar in behaviour to the electric field of an electric dipole.

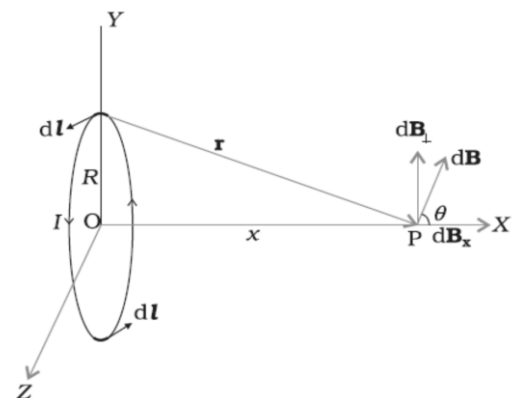

We have evaluated the magnetic field on the axis of a circular loop, of a radius R , carrying a steady current I .

The magnitude of this field is:

$$B = \frac{\mu_0 I R^2}{2(x^2 + R^2)^{3/2}}$$

Of the medium is important and its direction is along the axis and given by the right-hand thumb rule and we know if $x = 0$ then B is given by:

$$B_0 = \frac{\mu_0 I}{2R}$$

Permeability of the medium is important.

The figure shows:

The magnetic field lines for a current loop. The direction of the field is given by the right-hand thumb rule. The upper side of the loop may be thought of as the North Pole and the lower side as the south pole of a magnet.

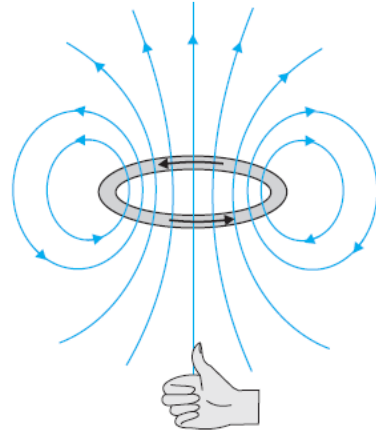

Here, x is the distance along the axis from the centre of the loop. For $x \gg R$, we may drop the R^2 term in the denominator. Thus

$$B = \frac{\mu_0 R^2}{2x^3}$$

Note that the area of the loop $A = \pi R^2$. Thus,

$$B = \frac{\mu_0 IA}{2\pi x^3}$$

As earlier, we define the magnetic moment m to have a magnitude IA ,

$m = IA$. Hence

$$B = \frac{\mu_0 m}{2\pi x^3} = \frac{\mu_0 \cdot 2m}{4\pi x^3}$$

The expression is very similar to an expression obtained earlier for the electric field of a dipole.

The similarity may be seen if we substitute,

$$\mu_0 \rightarrow \frac{1}{\epsilon_0}$$

$$m \rightarrow p_e \text{ (electrostatic dipole)}$$

$$B \rightarrow E \text{ (electrostatic field)}$$

We then obtain,

$$E = \frac{2p_e}{4\pi\epsilon_0 x^3}$$

which is precisely the field for an electric dipole at a point on its axis.

It can be shown that the above analogy can be carried further. We had found in Unit 1 of this course, that the electric field on the perpendicular bisector of the dipole is given by:

$$E = \frac{p_e}{4\pi\epsilon_0 x^3}$$

where x is the distance from the dipole. If we replace:

$$p \rightarrow m \text{ and } \mu_0 \rightarrow \frac{1}{\epsilon_0}$$

in the above expression, we obtain the result for B for **a point in the plane of the loop** at a distance x from the centre. For $x \gg R$,

$$B = \frac{\mu_0 m}{4\pi x^3}; \quad x \gg R$$

The results given by the above equations for value of B become exact for a **small** magnetic dipole.

The results obtained above apply to any planar loop:

A planar current loop is equivalent to a magnetic dipole of dipole moment $m = I A$, which is the analogue of electric dipole moment p .

THINK ABOUT THESE

How would the value of B change if the following change?

- **medium**
- **area of the loop**
- **orientation of the loop**
- **current in the loop**
- **direction of current in the loop**

Note: a fundamental difference:

An electric dipole is built up of two elementary units — the charges (or electric monopoles). In magnetism, a magnetic dipole (or a current loop) is the most elementary element. The equivalent of electric charges, i.e., magnetic monopoles, are not known to exist.

We have shown that a current loop:

- produces a magnetic field and behaves like a magnetic dipole at large distances
- is subject to torque like a magnetic needle.

This led Ampere to suggest that **all magnetism is due to circulating currents**.

This seems to be partly true and no magnetic monopoles have been seen so far. However, elementary particles such as an electron or a proton also carry an *intrinsic* magnetic moment, not accounted by circulating currents.

6. THE MAGNETIC DIPOLE MOMENT OF A REVOLVING ELECTRON

All electrons revolving in different orbits in atoms have an associated dipole moment for the magnetic field each electron creates.

Should the electrons be stationary there would be no magnetic field associated with it.

Should the electrons move with different speeds, the consequent current will be different and hence $m = I \times A$ will also be different.

You may perhaps have heard of the Bohr model which was proposed by the Danish physicist Niels Bohr in 1911 and was a stepping stone to a new kind of mechanics, namely, quantum mechanics.

In the Bohr model, for the hydrogen atom with only one electron, the electron (a negatively charged particle) revolves around a positively charged nucleus much as a planet revolves around the sun.

The force in the former case is electrostatic (Coulomb force) while it is gravitational for the planet-Sun case.

We show this Bohr picture of the electron in hydrogen atom

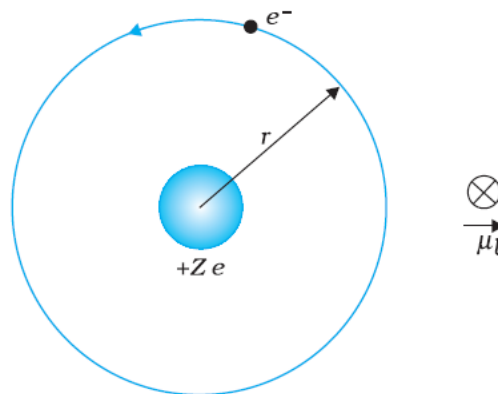

In the Bohr model of hydrogen-like atoms, the negatively charged electron is revolving with uniform speed around a centrally placed positively charged ($+Ze$) nucleus. The uniform circular motion of the electron constitutes a current. The direction of the magnetic moment is into the plane of the paper and is indicated separately by \otimes .

Let us find the magnetic moment

The electron of charge ($-e$)

($e = +1.6 \times 10^{-19}\text{C}$) performs uniform circular motion around a stationary heavy nucleus of charge $+Ze$. This constitutes a current I , where,

$$I = e/T$$

and T is the time period of revolution. Let r be the orbital radius of the electron, and v the orbital speed. Then,

$$T = 2\pi r/v$$

Substituting, we have

$$I = ev/2\pi r$$

There will be a magnetic moment, usually denoted by μ_l associated with this circulating current. From the equation its magnitude is:

$$\mu_l = I\pi r^2 = evr/2$$

The direction of this magnetic moment is into the plane of the paper given by the right hand rule and the fact that the negatively charge electron is moving anti-clockwise, leading to a clockwise current.

Multiplying and dividing the right-hand side of the above expression by the electron mass m_e , we have,

$$\mu_l = \frac{e}{2m_e} (m_e vr) = \frac{e}{2m_e} l$$

Here, l is the magnitude of the angular momentum of the electron about the central nucleus (“orbital” angular momentum). Vectorially

$$\mu_l = - \frac{e}{2m_e} l$$

The negative sign indicates that the angular momentum of the electron is opposite in direction to the magnetic moment.

Instead of electron with charge $(-e)$, if we had taken a particle with charge $(+q)$, the angular momentum and magnetic moment would be in the same direction. The ratio:

$$\frac{\mu_l}{l} = \frac{e}{2m_e}$$

It is called the **gyro magnetic ratio** and is a constant.

Its value is 8.8×10^{10} C /kg for an electron, which has been verified by experiments.

The fact that even at an atomic level there is a magnetic moment, confirms Ampere's bold hypothesis of atomic magnetic moments. This according to Ampere would help one to explain the magnetic properties of materials. Can one assign a value to this atomic dipole moment? The answer is yes. One can do so within the Bohr model. Bohr hypothesised that the angular momentum assumes a discrete set of values, namely:

$$l = \frac{nh}{2\pi}$$

where n is a natural number, $n = 1, 2, 3, \dots$ and h is a constant named after Max Planck (Planck's constant) with a value $h = 6.626 \times 10^{-34}$ J s.

This condition of discreteness is called the **Bohr quantisation condition**.

We shall discuss it in detail later in course 4 here our aim is merely to use it to calculate the elementary dipole moment.

Take the value $n = 1$, we have

$$(\mu_l)_{\min} = \frac{e}{4\pi m_e} h = \frac{1.60 \times 10^{-19} \times 6.63 \times 10^{-34}}{4 \times 3.14 \times 9.11 \times 10^{-31}} = 9.27 \times 10^{-24} \text{ A m}^2$$

where the subscript 'min' stands for minimum. This value is called the **Bohr magnetron**.

Any charge in uniform circular motion would have an associated magnetic moment. This dipole moment is labelled as the *orbital magnetic moment*.

Hence the subscript ' l ' in μ_l .

Besides the orbital moment, the electron has an **intrinsic** magnetic moment; it is called the **spin magnetic moment**. You will come across these terms in your chemistry courses as well.

7. BAR MAGNET AS AN EQUIVALENT SOLENOID

We have learnt how a current loop acts as a magnetic dipole. We mentioned Ampere's hypothesis that all magnetic phenomena can be explained in terms of circulating currents.

The magnetic dipole moment m associated with a current loop was defined to be

$$m = NI A$$

where

N is the number of turns in the loop,

I the current and

A the area vector

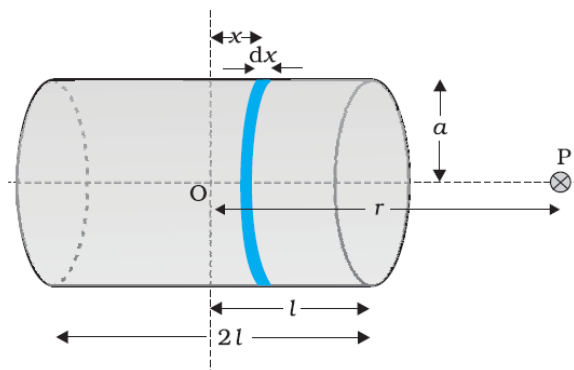

The axial field of a finite solenoid in order to demonstrate its similarity to that of a bar magnet.

The resemblance of magnetic field lines for a bar magnet and a solenoid suggest that a bar magnet may be thought of as a large number of circulating currents in analogy with a solenoid.

Cutting a bar magnet in half is like cutting a solenoid. We get two smaller solenoids with weaker magnetic properties. The field lines remain continuous, emerging from one face of the solenoid and entering into the other face. One can test this analogy by moving a small compass needle in the neighbourhood of a bar magnet and a current-carrying finite solenoid and noting that the deflections of the needle are similar in both cases.

To make this analogy more firm we calculate the axial field of a finite solenoid depicted in Fig. We shall demonstrate that at large distances this axial field resembles that of a bar magnet.

Let the solenoid in above fig. consists of n turns per unit length. Let its length be $2l$ and radius a .

We can evaluate the axial field at a point P, at a distance r from the centre O of the solenoid. To do this, consider a circular element of thickness dx of the solenoid at a distance x from its centre. It consists of $n dx$ turns. Let I be the current in the solenoid.

In our earlier considerations, we have calculated the magnetic field on the axis of a circular current loop.

The magnitude of the field at point P due to the circular element is:

$$dB = \frac{\mu_0 n dx I a^2}{2[(r-x)^2 + a^2]^{3/2}}$$

The magnitude of the total field is obtained by **summing over all the elements** — in other words by integrating from $x = -l$ to $x = +l$.

Thus,

$$B = \frac{\mu_0 n I a^2}{2} \int_{-l}^{+l} \frac{dx}{[(r-x)^2 + a^2]^{3/2}}$$

This integration can be done by trigonometric substitutions. This exercise, however, is not necessary for our purpose. Note that the range of x is from $-l$ to $+l$.

Consider the far axial field of the solenoid, i.e. $r \gg a$ and $r \gg l$. Then the denominator is approximated by:

$$[(r-x)^2 + a^2]^{3/2} \approx r^3$$

$$\text{And } B = \frac{\mu_0 n I a^2}{2r^3} \int_{-l}^{+l} dx = \frac{\mu_0 n I 2l a^2}{2r^3}$$

Note that the magnitude of the magnetic moment of the solenoid is,

$$m = n(2l)I (\pi a^2)$$

Which is (total number of turns \times current \times cross-sectional area).

Thus,

$$B = \frac{\mu_0}{4\pi} \frac{2m}{r^3}$$

This is also the far axial magnetic field of a bar magnet which one may obtain experimentally.

Thus, a bar magnet and a solenoid produce similar magnetic fields.

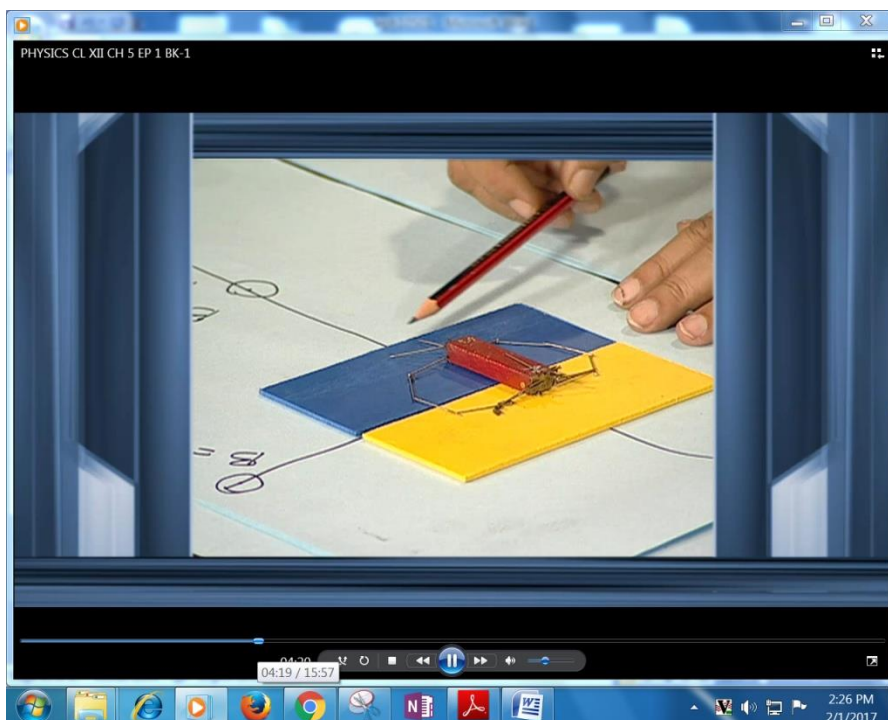

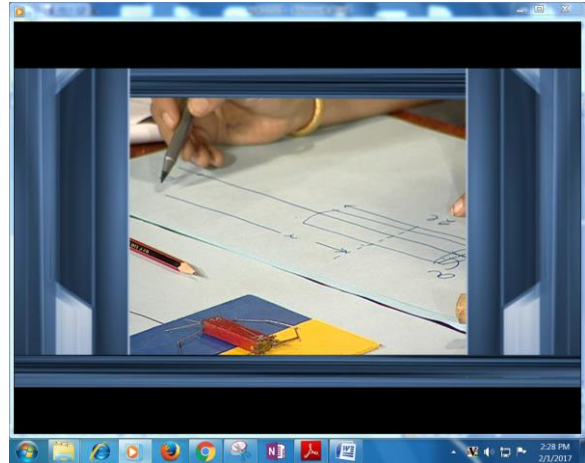
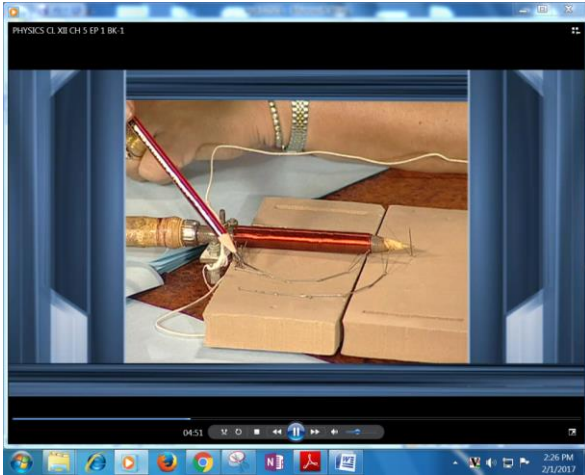

The magnetic moment of a bar magnet is thus equal to the magnetic moment of an equivalent solenoid that produces the same magnetic field.

CONSIDER THIS

Some textbooks assign a **magnetic charge** (also called *pole strength*) $+q_m$ to the north pole and $-q_m$ to the south pole of a bar magnet of length $2l$, and magnetic moment $q_m(2l)$.

The field strength due to q_m at a distance r from it is given by: $\frac{\mu_0 q_m}{4\pi r^2}$

The magnetic field due to the bar magnetic then obtained, both for the axial and the equatorial case, in a manner analogous to that of an electric dipole.

The method is simple and appealing.

However, magnetic monopoles do not exist, and we have avoided this approach for that reason.

8. THE MAGNETIC DIPOLE IN A UNIFORM MAGNETIC FIELD

OR

TORQUE ON A CURRENT LOOP IN A UNIFORM MAGNETIC FIELD

The pattern of iron filings, i.e., the magnetic field lines gives us an approximate idea of the magnetic field B . We may at times be required to determine the magnitude of B accurately.

This is done by placing a small compass needle of known magnetic moment m and moment of inertia I and allowing it to oscillate in the magnetic field.

This arrangement is shown in the figure

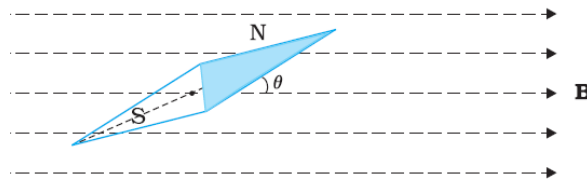

A magnetic needle in a uniform magnetic field B . The arrangement may be used to determine either B or the magnetic moment m of the needle.

The torque on the needle is:

$$\tau = m \times B$$

In magnitude:

$$\tau = mB \sin\theta$$

Here τ is restoring torque and θ is the angle between m and B .

Therefore, in equilibrium:

$$I \frac{d^2\theta}{dt^2} = -mB \sin\theta$$

Negative sign with $mB \sin\theta$ implies that restoring torque is in opposition to deflecting torque.

For small values of θ in radians, we approximate $\sin \theta \approx \theta$ and get:

$$I \frac{d^2\theta}{dt^2} \approx -mB\theta$$

$$\frac{d^2\theta}{dt^2} = -\frac{mB}{I}\theta$$

This represents a simple harmonic motion. The square of the angular frequency is

$$\omega^2 = mB/I$$

and the time period is:

$$T = 2\pi \sqrt{\frac{I}{mB}}$$

$$B = \frac{4\pi^2 I}{mT^2}$$

An expression for magnetic potential energy can also be obtained on lines similar to electrostatic potential energy.

The magnetic potential energy U_m is given by:

$$U_m = \int \tau(\theta) d\theta = \int mB \sin\theta = -mB \cos\theta = -\mathbf{m} \cdot \mathbf{B}$$

We have emphasised in Unit 1 on electrostatics that the zero of potential energy can be fixed at one's convenience.

Taking the constant of integration to be zero means fixing the zero of potential energy at $\theta = 90^\circ$, i.e., when the needle is perpendicular to the field.

The above equation shows that potential magnetic potential energy is: minimum ($= -mB$) at $\theta = 0^\circ$ (most stable position) and maximum ($= +mB$) at $\theta = 180^\circ$ (most unstable position).

EXAMPLE

Suppose the magnetic needle has magnetic moment $6.7 \times 10^{-2} \text{ Am}^2$ and moment of inertia $I = 7.5 \times 10^{-6} \text{ kg m}^2$. It performs 10 complete oscillations in 6.70 s.

What is the magnitude of the magnetic field?

SOLUTION

The time period of oscillation is:

$$T = \frac{6.70}{10} = 0.67 \text{ s}$$

$$B = \frac{4\pi^2 I}{mT^2}$$

$$= \frac{4 \times (3.14)^2 \times 7.5 \times 10^{-6}}{6.7 \times 10^{-2} \times (0.67)^2}$$

$$= 9.83 \times 10^{-3} \text{ T}$$

If instead of the magnet or small magnetic needle we had a current loop which, could rotate freely due to the torque.

So let us reconsider **torque on a rectangular current loop in a uniform magnetic field**

A rectangular loop ($a \times b$) carrying a steady current I and placed in a uniform magnetic field B experiences a torque.

POINTS TO NOTE

- Fig (a) shows the loop ABCD ($a \times b$) is placed between the poles of a permanent magnet (say a horse shoe magnet)
- Uniform field \mathbf{B} is directed from north to south pole
- 'a' is the width of the rectangular loop and 'b' is the length
- The field exerts no force on the two arms AD and BC of the loop as they are parallel
- The field is perpendicular to the arm AB and CD of the loop and exerts a force F_1 on AB which is directed into the plane of the loop.
- Its magnitude is, $F_1 = I b B$ (from Lorentz force)
- It exerts a force F_2 on the arm CD
- F_2 is directed out of the plane of the paper.

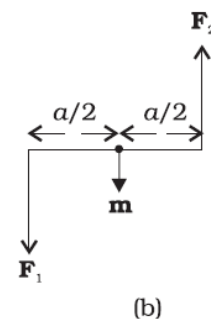
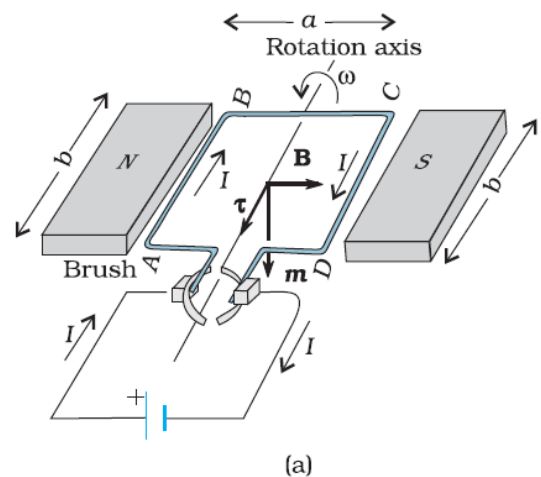

- $F_2 = I b B = F_1$
- Thus, the *net force on the loop is zero*.
- There is a *torque on the loop due to the pair of forces F_1 and F_2* .
- Figure shows a view of the loop from the AD end.
- It shows that the torque on the loop tends to rotate it anti-clockwise.
- This torque is (in magnitude):

$$\tau = m \times B$$

$$= I A B A = (a \times b)$$

- As long as the field \mathbf{B} is constant torque remains the same for a steady current I
- Torque τ vanishes when \mathbf{m} is either parallel or anti parallel to the magnetic field \mathbf{B} . This indicates a state of equilibrium as there is no torque on the coil
Any small rotation of the coil produces a torque which brings it back to its original position.
When they are anti parallel, the equilibrium is unstable as any rotation produces a torque which increases with the amount of rotation.
The presence of this torque is also the reason why a small magnet or any magnetic dipole aligns itself with the external magnetic field.
- If the loop has N closely wound turns, the expression form $= N I A$

EXAMPLE

A 100 turn closely wound circular coil of radius 10 cm carries a current of 3.2 A.

(a) What is the field at the centre of the coil?

(b) What is the magnetic moment of this coil?

The coil is placed in a vertical plane and is free to rotate about a horizontal axis which coincides with its diameter. A uniform magnetic field of 2T in the horizontal direction exists such that initially the axis of the coil is in the direction of the field. The coil rotates through an angle of 90° under the influence of the magnetic field.

(c) What are the magnitudes of the torques on the coil in the initial and final position?

SOLUTION:

$$\text{a) } B = \frac{\mu_0 NI}{2R}$$

Substituting:

$$B = \frac{4\pi \times 10^{-7} \times 3.2 \times 10^2}{2 \times 10^{-1}} = \frac{4 \times 10^{-5} \times 10}{2 \times 10^{-1}} = 2 \times 10^{-3} \text{ T}$$

The direction is given by the right-hand thumb rule.

(b) The magnetic moment is given by:

$$m = NIA = NI\pi r^2 = 100 \times 3.2 \times 3.14 \times 10^{-2} = 10 \text{ A m}^2$$

The direction is given by right hand thumb rule

$$\text{b) } \tau = |\mathbf{m} \times \mathbf{B}| = mB\sin\theta$$

Initially, $\theta = 0$.

Thus, initial torque $\tau_i = 0$.

Finally, $\theta = \pi/2$ (or 90°).

Thus, final torque $\tau_f = mB = 10 \times 2 = 20 \text{ N m}$.

This can be imagined by suspending a magnetic needle between the pole pieces of a horse shoe magnet

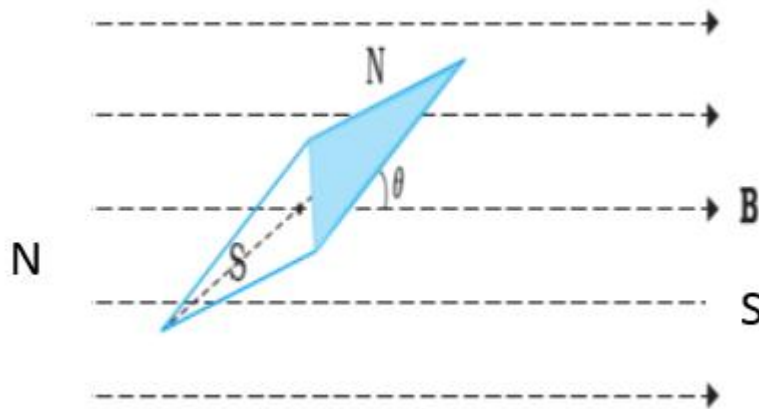

The torque on the needle will cause it to rotate symmetrically about the pivot.

EXAMPLE

(a) A current-carrying circular loop lies on a smooth horizontal plane.

Can a uniform magnetic field be set up in such a manner that the loop turns around itself (i.e., turns about the vertical axis).

(b) A current-carrying circular loop is located in a uniform external magnetic field. If the loop is free to turn, what is its orientation of stable equilibrium? Show that in this orientation, the flux of the total field (external field + field produced by the loop) is maximum.

(c) A loop of irregular shape carrying current is located in an external magnetic field. If the wire is flexible, why does it change to a circular shape?

SOLUTION

(a) No, because that would require the torque to be in the vertical direction.

But torque = $I \mathbf{A} \times \mathbf{B}$, and since \mathbf{A} of the horizontal loop is in the vertical direction, torque would be in the plane of the loop for any \mathbf{B} .

(b) Orientation of stable equilibrium is one where the area vector \mathbf{A} of the loop is in the direction of external magnetic field. In this orientation, the magnetic field produced by the loop

is in the same direction as external field, both normal to the plane of the loop, thus giving rise to maximum flux of the total field.

(c) It assumes circular shape with its plane normal to the field to maximize flux, since for a given perimeter, a circle encloses greater area than any other shape.

A COMPARISON BETWEEN ELECTRIC AND MAGNETIC DIPOLE

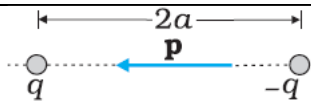
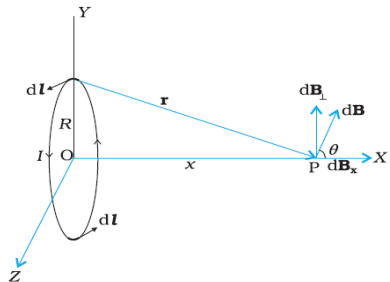
	Electric dipole	Magnetic dipole
Definition	A pair of equal and opposite charges q and $-q$ separated by a small distance $2a$	A closed circulation of electron, charge or current in a planar loop
Dipole moment	<p>Electric dipole is characterised by dipole moment p</p> <p>$p=2aq$</p> <p>q is the charge separation between positive and negative charges = $2a$</p> <p>direction of dipole moment from negative to positive</p> <p>unit Cm</p> <p>p is a vector</p>	<p>Magnetic dipole is characterised by magnetic moment m</p> <p>$m = I \times A$</p> <p>I is the current or rate of flow of charge</p> <p>A area of the loop</p> <p>direction given by right hand rule</p> <p>unit Am^2</p> <p>m is a vector</p>
diagram		
Dipole field	E	B

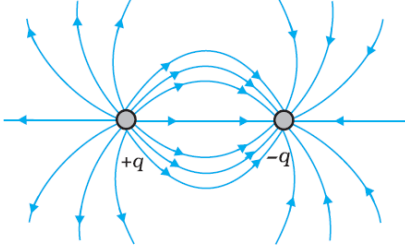
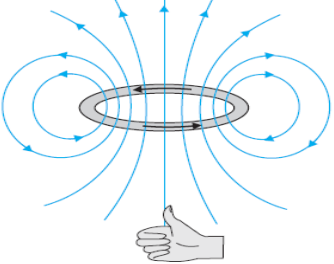
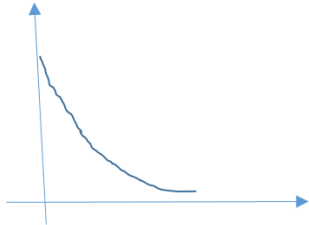
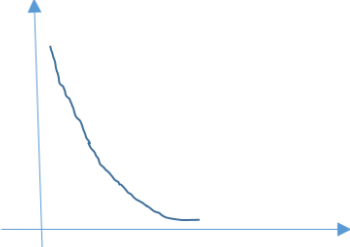
	SI unit : N/C	SI unit : newton second/coulomb meter $\text{NsC}^{-1} \text{m}^{-1}$ or Tesla
Field lines	 <p>Field lines emerge at + ve charge and enter at _ve charge</p>	 <p>Field lines form closed loops</p>
Formulae	<p>At a point on the dipole axis:</p> $E = \frac{2p_e}{4\pi\epsilon_0 x^3} \quad (r \gg a)$ <p>At a point on the equatorial plane:</p> $E = -\frac{p_e}{4\pi\epsilon_0 x^3} \quad (r \gg a)$ <p>R is the distance of the point from the centre of the dipole</p>	<p>At a point along the axis passing through the centre and perpendicular to the plane of the loop:</p> $B = \frac{\mu_0 2m}{4\pi x^3} \quad (x \gg R)$ <p>R is the radius of the loop</p> <p>B at a point in the plane of the loop at a distance x from the centre of the loop</p> $B = \frac{\mu_0 m}{4\pi x^3} \quad (x \gg R)$
Graph E vs r E proportional to $1/r^3$		

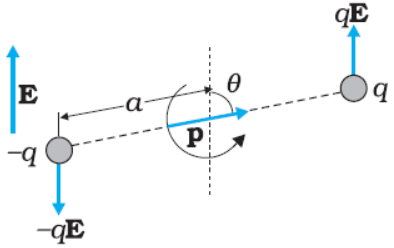
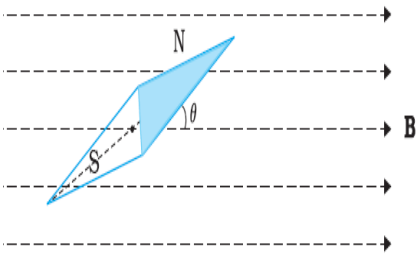

Effect of uniform external field	<p>No net force acts on the dipole</p> <p>Torque given by $\mathbf{p} \times \mathbf{E}$</p> <p>Dipole rotates about a symmetrical axis to come in stable equilibrium</p>  <p>Electrostatic potential energy stored in case electric dipole is held by a restoring torque</p> <p>$\mathbf{p} \cdot \mathbf{E} = pE \cos \theta$</p>	<p>No net force acts on the dipole</p> <p>Torque given by $\mathbf{m} \times \mathbf{B}$</p> <p>Dipole rotates about a symmetrical axis to come in stable equilibrium</p>  <p>Magnetic potential energy stored in case magnetic dipole is held by a restoring torque</p> <p>$\mathbf{m} \cdot \mathbf{B} = m B \cos \theta$</p>
Importance of medium around the dipole Remember $\mu\epsilon = 1/v^2$ or $\mu_0\epsilon_0 = 1/c^2$	<p>Permittivity of material ϵ</p> <p>For free space or vacuum ϵ_0</p> <p>since E along the axis say at a distance of x from the centre of dipole</p> $E = \frac{p_e}{4\pi\epsilon_0 x^3}$	<p>Permeability of material μ</p> <p>For free space or vacuum μ_0</p> <p>since B along the axis say at a distance of x from the centre of a current loop:</p> $= \frac{\mu_0 2m}{4\pi x^3}$

9. APPLICATION OF TORQUE ON A MAGNETIC DIPOLE IN A UNIFORM MAGNETIC FIELD

We consider some simple applications from daily life

a) Compass needle

Compass needle is a small magnetic dipole, when it is placed in earth's magnetic field it has a torque acting on it and the same brings it in its least PE stat .thus the needle aligns in the direction of the external field.

Compass needles are widely used for determining direction (north -south), to check whether a magnet or magnetic field generating element is in the vicinity.

Experiments with magnetism usually make use of compass needles

b) Galvanometers ammeters and voltmeters

A current carrying conductor experiences a torque when placed in an external uniform magnetic field

We have seen from our study in this unit that the torque is proportional to the current through the coil, if the area of the coil (A) and number of turns (N) is constant So you use this phenomenon to make a device that can

- i) detect current
- ii) detect the direction of current
- iii) estimate the magnitude of current

The device working on the above principle is a moving coil galvanometer.

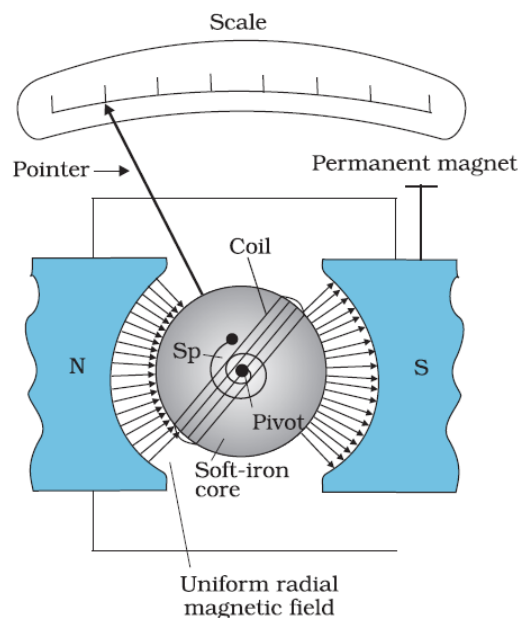

The galvanometer consists of a coil, with many turns, free to rotate about a fixed axis .the coil is placed in a uniform radial magnetic field. There is a cylindrical soft iron core which not only

makes the field radial but also increases the strength of the magnetic field because soft iron has greater permeability.

When a current flows through the coil, a torque acts on it. This torque is given:

$$\tau = m \times B \quad \text{or} \quad \tau = NIAB$$

where the symbols have their usual meaning. Since the field is radial by design.

The magnetic torque $NIAB$ tends to rotate the coil. A spring \mathbf{Sp} provides a counter torque $k\phi$ that balances the magnetic torque $NIAB$; resulting in a steady angular deflection ϕ .

In equilibrium:

$$K\phi = NIAB$$

where k is the torsional constant of the spring; i.e. the restoring torque per unit twist.

The deflection ϕ is indicated on the scale by a pointer attached to the spring.

By making suitable changes we can convert a moving coil galvanometer to read currents and voltages.

These devices are called ammeters and voltmeters details of the design you must have considered in another dedicated module in the unit.

c) Electric motors

Another useful application of torque developed on a current carrying coil when placed in a magnetic field.

Imagine all the motors that you have ever seen or used, toys motors, fans, mixers, grinders, atta chaki (grinding machine to make wheat flour) etc. Think about situations when there is no electricity!!!

10. MAGNETISM AND GAUSS'S LAW

In unit 1 we studied Gauss's law for electrostatics.

In the figure we see that for a closed surface represented by (i) the number of lines leaving the surface is equal to the number of lines entering it. This is consistent with the fact that no net charge is enclosed by the surface.

However, in the same figure, for the closed surface (ii) there is a net outward flux, since it does include a net (positive) charge.

The situation is radically different for magnetic fields which are continuous and form closed loops. Examine the Gaussian surfaces represented by (i) or (ii) in Fig. Both cases visually demonstrate that the number of magnetic field lines leaving the surface is balanced by the number of lines entering it.

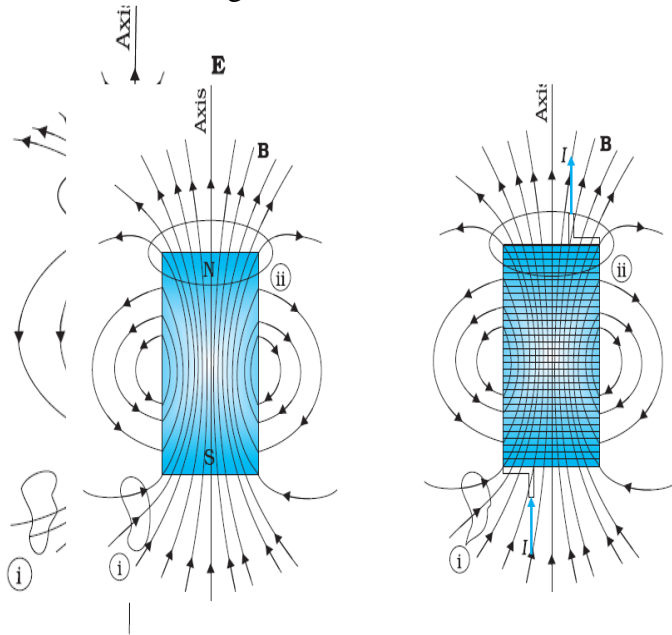

The net magnetic flux is zero for both the surfaces. This is true for any closed surface:

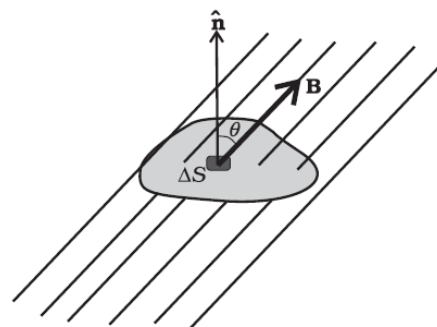

Consider a small vector area element ΔS of a closed surface S as in the Fig. The magnetic flux through ΔS is defined as

$$\Delta\phi_B = \mathbf{B} \cdot \Delta\mathbf{S} \quad \text{where } \mathbf{B} \text{ is the field at } \Delta\mathbf{S}$$

We divide S into many small area elements and calculate the individual flux through each. Then, the net flux ϕ_B is:

$$\phi_B = \sum_{all} \Delta\phi_B = \sum_{all} B\Delta S = 0$$

where 'all' stands for 'all area elements ΔS . Compare this with the Gauss's law of electrostatics. The flux through a closed surface in that case is given by:

$$\sum E\Delta S = \frac{q}{\epsilon_0}$$

where q is the electric charge enclosed by the surface.

The difference between the Gauss's law of magnetism and that for electrostatics is a reflection of the fact that isolated magnetic poles (also called monopoles) are not known to exist. There are no sources or sinks of B ; the simplest magnetic element is a dipole or a current loop.

All magnetic phenomena can be explained in terms of an arrangement of dipoles and/or current loops.

Thus, Gauss's law for magnetism is:

The net magnetic flux through any closed surface is zero.

11. SUMMARY

- The science of magnetism is old. It has been known since ancient times that magnetic materials tend to point in the north-south direction; like magnetic poles repel and unlike ones attract; and cutting a bar magnet in two leads to two smaller magnets.
- Magnetic poles cannot be isolated.
- A current loop is the basic magnetic dipole
- Magnetic moment of a dipole, $\mathbf{m} = \mathbf{I} \times \mathbf{A}$, it is a vector, direction is given by right hand grip rule
- There is an amazing similarity between an electric dipole and a magnetic dipole
- When an electric dipole of dipole moment p is placed in a uniform electric field E ,
(a) the force on it is zero,

- (b) the torque on it is $\mathbf{p} \times \mathbf{E}$,
 - (c) its potential energy is $-\mathbf{p} \cdot \mathbf{E}$ where we choose the zero of energy at the orientation when \mathbf{m} is perpendicular to \mathbf{E} .
-
- When a bar magnet of dipole moment \mathbf{m} is placed in a uniform magnetic field \mathbf{B} ,
 - (a) the force on it is zero,
 - (b) the torque on it is $\mathbf{m} \times \mathbf{B}$,
 - (c) its potential energy is $-\mathbf{m} \cdot \mathbf{B}$, where we choose the zero of energy at the orientation when \mathbf{m} is perpendicular to \mathbf{B} .
-
- Magnets or magnetic dipoles are used in a variety of useful ways.